

Datasheet

Gas Discharge Tube (GDT)

Series / Models	2R3000T-8
Product Code	10.12.88.3020-V2850-3500
Version	A0
Date	2025-07-16
File Number	SP-GDT-312

Gas Discharge Tube (GDT)

2R3000T-8

Version History

Version	Date	Page	Description	Author
A0	2025-07-16	/	official release	Xia Wu

Gas Discharge Tube (GDT)

2R3000T-8

Description

Gas discharge tubes (GDTs) are generally in a high insulation resistance state, equivalent to an open circuit, which has almost no impact on the normal operation of the circuit. When transient overvoltage occurs in the circuit and the voltage amplitude exceeds the breakdown voltage of the GDT, the gas inside the GDT is ionized, causing the GDT to quickly conduct and limit the overvoltage to a lower level, thereby protecting electronic devices or circuit components connected in parallel from high voltage impact damage. After the overvoltage disappears, the GDT immediately returns to a high insulation resistance state, and the circuit resumes normal operation.

The 2R3000T-8 GDT is an axial leads component. It is not only small in size and easy to install on various compact printed circuit boards (PCBs), but also has excellent performance. High AC withstand voltage and high insulation resistance ensure that the performance of the circuit will not suffer additional losses under normal operating conditions. The 2R3000T-8 GDT is a high-voltage component designed specifically for surge protection and high isolation applications. It is also suitable for applications where there is typically a bias voltage or signal level of several hundred volts. It can also be combined with MOVs to provide excellent protection performance for AC applications.

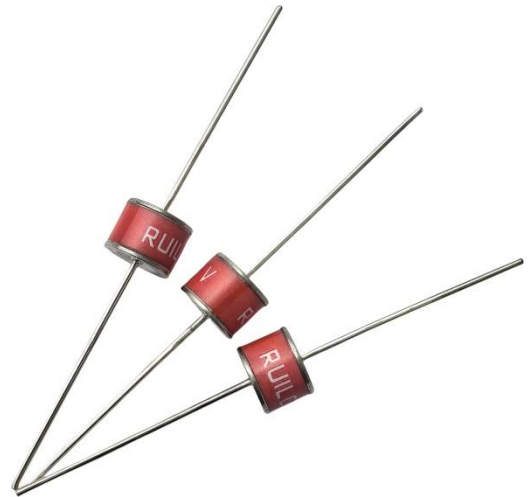

Electrical symbol

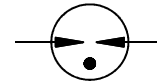

Features

- I Voltage Ranges 3000V
- I Excellent response to fast rising transients
- I 8/20 μ s Impulse current capability: 5KA
- I Non-Radioactive
- I Ultra Low capacitance (<1.5pF)
- I Size: Φ 8mm*6mm

Applications

Automotive:

- I On-board chargers
- I Vehicle charging stations

Others:

- I LED lighting
- I Power supply
- I Photovoltaic
- I Air conditioning



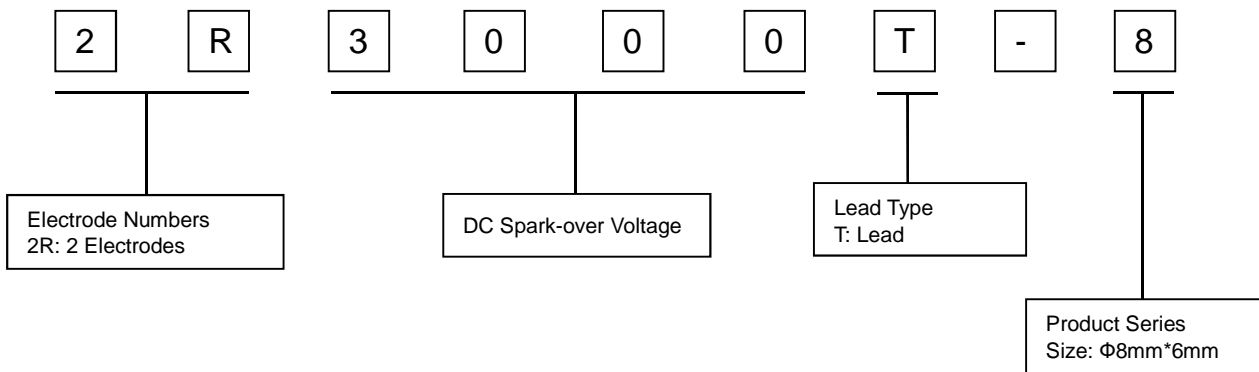

Part Number Code



Gas Discharge Tube (GDT)

2R3000T-8

Electrical Characteristics

DC Spark-over Voltage ^{1) 2)}	at 100V/S	2850~3500	V
Impulse Spark-over Voltage	at 100V/μS	<3800	V
	at 1KV/μS	<4000	V
Service life			
Impulse Discharge Current	8/20μS	±5 times	5
	8/20μS	1 time	10
Alternating Discharge Current	50Hz, 1S	10 times	2.5
Insulation Resistance	at DC 100V	>1	GΩ
Capacitance	at 1MHz	<1.5	pF
Glow Voltage	at 10mA	~260	V
Arc Voltage	at 1A	~30	V
Glow to Arc transition current		~0.5	A
AC Withstand Voltage	at 5mA 1Min	1600	V
Weight		~1.2	g
Operation and storage temperature		-40~+125	°C
Climatic category (IEC60068-1)		40/125/21	
Certifications		 US UL1449 E479668  UL1449 E508408  EN 61643-311 J50571931  IEC 61643-311	
Marking, red negative		RUILON 3000 Y 3000 -Nominal voltage Y -Year of production	
Surface treatment		Nickel Plated	
Moisture sensitivity level ³⁾		1	

¹⁾ At delivery AQL 0.65 level II, DIN ISO 2859

²⁾ In ionized mode

³⁾ Tests according to JEDEC J-STD-020.

Terms in accordance with ITU-T Rec. K.12, IEC 61643-311, GB/T 18802.311, GB/T 9043.

Gas Discharge Tube (GDT)

2R3000T-8

Dimensions(unit: mm/inch)

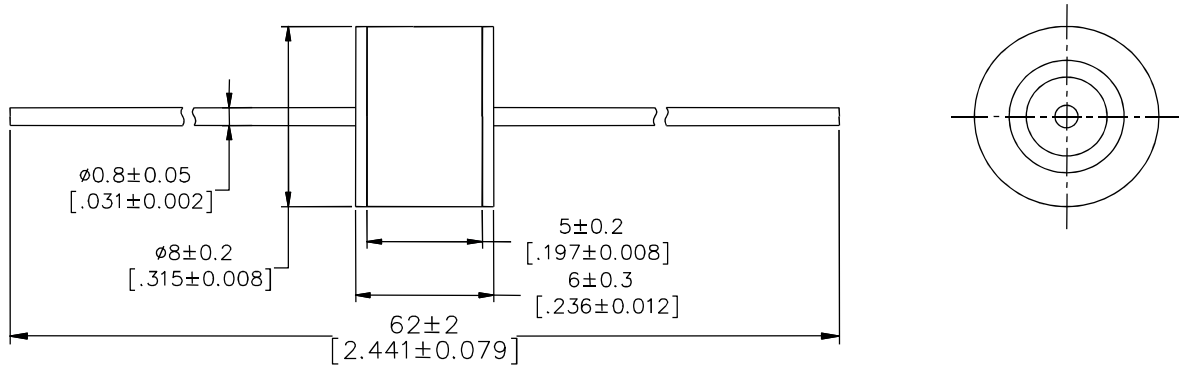

Packaging Information

Tape

Reel

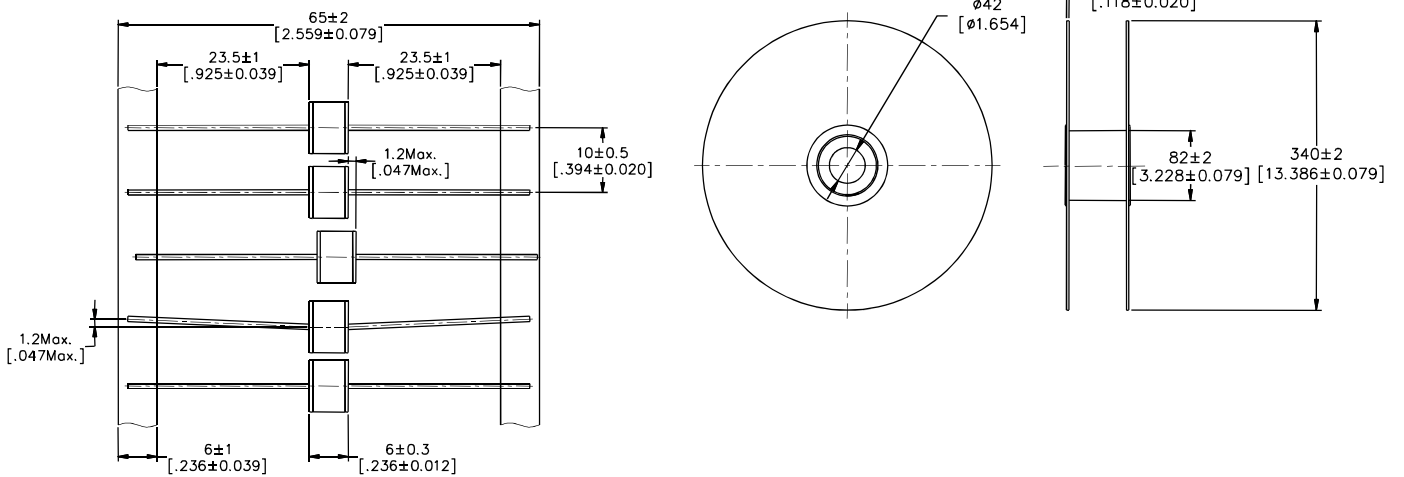

According to IEC 60286-1

Gas Discharge Tube (GDT)

2R3000T-8

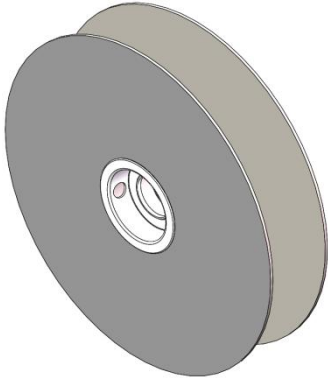
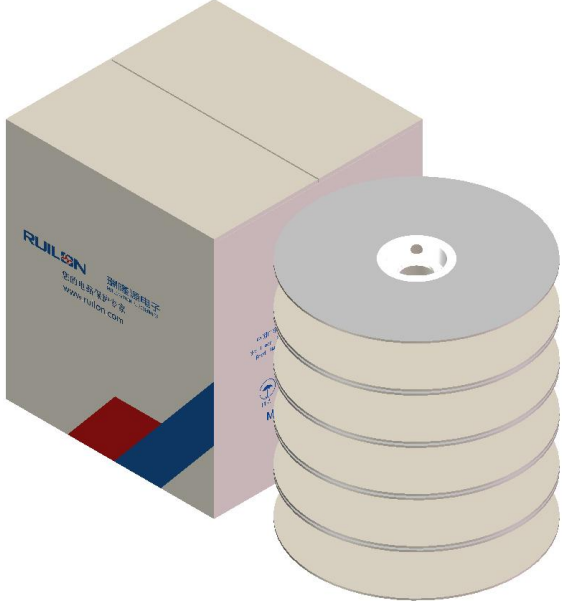
	Reel	Carton
Size	340×78mm	350×350×407mm
Quantity	MPQ/MOQ: 1 reel=800pcs	1 Carton=5 reels =4,000pcs
Photos		

Soldering Parameters - Wave soldering (Thru-Hole Devices)

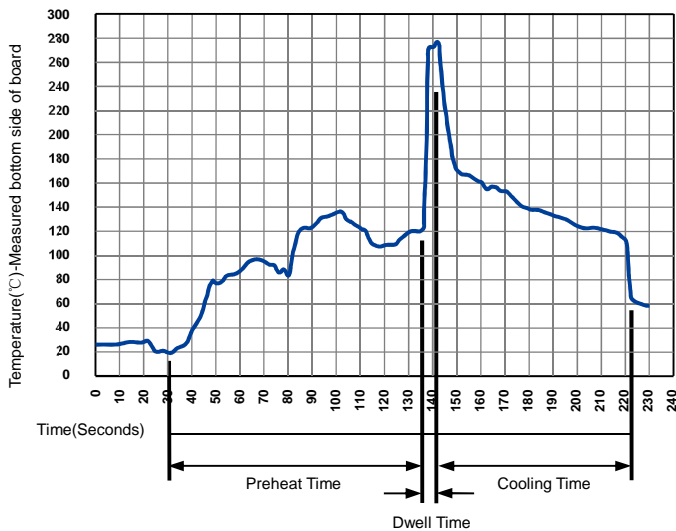

Wave Soldering Condition		Pb-Free assembly
Preheat	Temperature Min	100°C
	Temperature Max	150°C
	Time (Min to Max)	60-180 Seconds
Solder Pot Temperature		280°C Max
Solder Dwell Time		2-5 Seconds

Gas Discharge Tube (GDT)

2R3000T-8

Terms and definitions

NO.	Item	Definitions
1	Gas discharge tube(GDT)	A gap, or several gaps, in an enclosed discharge medium, other than air at atmospheric pressure, designed to protect apparatus or personnel, or both, from high transient voltages. Also referred to as "gas tube surge arrester".
2	DC Spark-over Voltage	The voltage at which the gas discharge tube sparks over with slowly increasing d.c. voltage.
3	Impulse Spark-over Voltage	The highest voltage which appears across the terminals of a gas discharge tube in the period between the application of an impulse of given wave-shape and the time when current begins to flow.
5	Arc voltage	Voltage drop across the GDT during arc current flow.
6	Glow voltage	Peak value of voltage drop across the GDT when a glow current is flowing.
7	Impulse discharge current 8/20μs	Current impulse with a nominal virtual front time of 8 μ s and a nominal time to half-value of 20 μ s.
8	Alternating Discharge Current	The rms value of an approximately sinusoidal alternating current passing through the gas discharge tube.
9	Insulation Resistance	Insulation resistance shall be measured from each terminal to every other terminal of the GDT. The test is performed with DC50V when normal spark-over Voltage 70~150V, others with DC100V.
10	Capacitance	The capacitance shall be measured once at 1 MHz between all terminals unless otherwise specified.

Cautions

- I Do not operate Gas discharge tubes in power supply networks, whose maximum operating voltage exceeds the minimum spark-over voltage of the surge arresters.
- I Gas discharge tubes may become hot in the event of longer periods of current stress (burn risk). In the event of overload the connectors may fail or the component may be destroyed.
- I Electromagnetic fields and ionizing radiation may affect the electrical characteristics of the gas discharge tubes. The impact of such effects (inductive and capacitive field distortion from adjacent components) must be avoided by appropriate circuit design measures.
- I If the contacts of the gas discharge tubes are defective, current load can cause sparks and loud noises.
- I Gas discharge tubes must be handled with care and must not be dropped.
- I Damaged gas discharge tubes must not be re-used.
- I The electrical characteristics described in this datasheet are only typical characteristics, and all of these characteristics have been confirmed through testing and inspection. If the customer's usage requirements are different from this or have special requirements, please contact Ruilongyuan Electronics Co., Ltd. If protection failure or circuit damage occurs as a result, our company is not responsible for it.
- I Ruilongyuan Electronics Co., Ltd. always strives to improve our products. Consequently, the products described in this datasheet may be updated from time to time, and the corresponding product specifications may also be updated accordingly. So, before or at the time of placing your order, please check to what extent the product descriptions and specifications contained in this publication are still applicable. Ruilongyuan Electronics Co., Ltd. still reserves the right to cease production and delivery of products. Consequently, we cannot guarantee that all products listed in this datasheet will always be available. The above provisions do not apply to individual agreements with customers for specific products.
- I Ruilongyuan Electronics Co., Ltd. models may have different product codes. Different product code representations are due to the use of different production processes, but do not affect their respective product specifications.